

HIGH SECURITY FOOD PASS ANTI - SPLASH SYSTEM



A HIGH SECURITY FOOD PASS AND ANTI-SPLASH SYSTEM

- The High Security Food Pass and Anti-Splash Box System was designed by *On the Gate* for use in access-sensitive areas on swinging and sliding doors.
- By replacing a standard cell door food slot with the High Security Food Pass and Anti-Splash Box System, assaults to personnel are virtually eliminated. The system also helps to prevent the spread of contagious diseases by reducing contact between inmates and facility personnel.
- There is no need to replace existing doors; the system was developed for use in retrofit applications and can be mounted to existing doors.

STANDARD FEATURES

- Constructed of tough and corrosion resistant 304 Stainless Steel.
- Incorporates a fully removable Clear Lexan Polycarbonate Anti-Splash Box. The Anti-Splash Box is fully interchangeable and transferable from one door to another with the High Security Food Pass Frame/Door Assembly installed.
- Features the only automatic self-opening food pass door. Key operation unlocks the food pass and allows the door to automatically rise halfway. The door can then be manually raised to the fully open position, or any other desired position. The door can be manually closed to any position or closed halfway with a turn of the key. In any position, a ratcheting system does not allow door to be forced open.
- A positive “Anti-Splash Box to Frame Mating System” creates a snug seal to minimize any gaps between the frame and box.
This prevents the splashing of liquids.
- Airteq 5017 paracentric locks are included with the system.



2511 Midpark Road, Montgomery, AL 36109
Phone: 800-466-3007 Fax: (334) 286-6421

Revised 04/03/2025

TECHNICAL SPECIFICATIONS

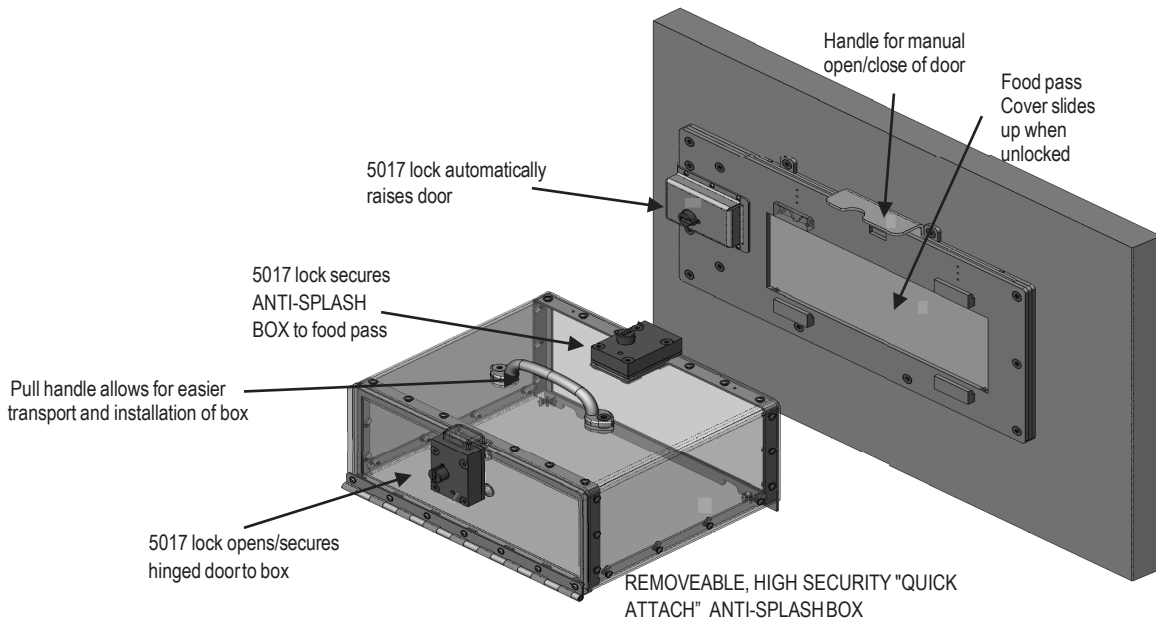
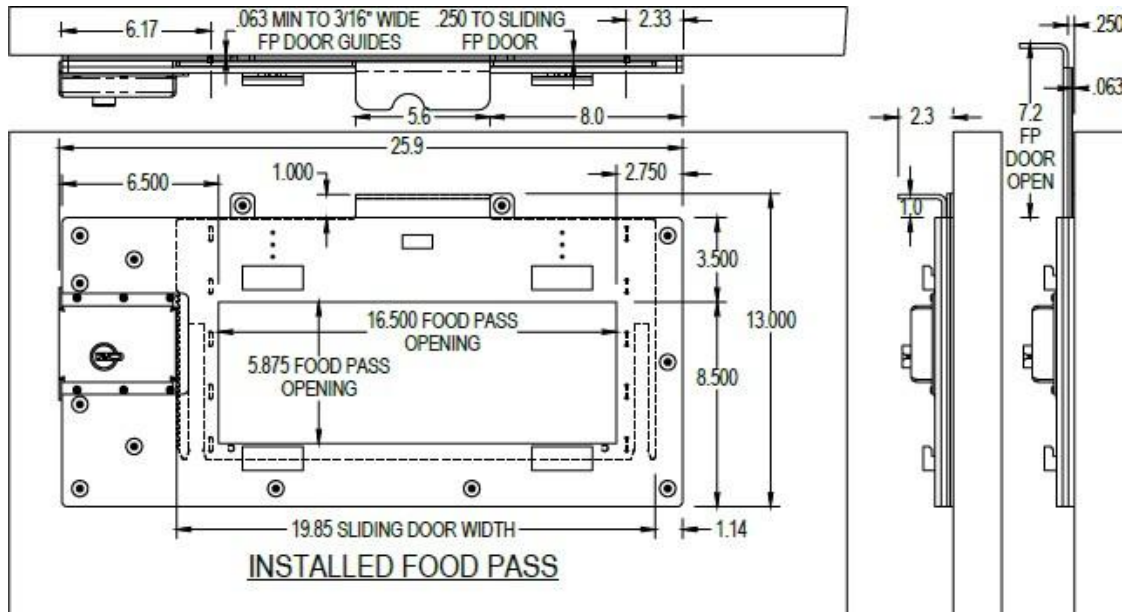

DOOR SHOWN WITH ANTI-SPLASH BOX REMOVED

NOTE: Illustrations are for informational use only. Do not use for construction.

- **Base Frame:** 304 Stainless steel polished construction
- **Anti-splashFrame:** 304 Stainless steel with tamper resistant screws
- **Anti-splash box:** Lexan polycarbonate cover
- **Hydraulic Spring**
- **ADA Compliant**

Warranty

Airteq warrants its products against defects in material or workmanship for one year from the time of delivery. Airteq's sole obligation under the warranty is to repair, or at its option, to replace the product. The buyer shall have no other remedy. (All special, incidental and coincidental damages are excluded.) Written notice of breach of warranty must be given to Airteq within the warranty period. The warranty does not cover damages resulting from improper installation or maintenance, accident or misuse. NO OTHER WARRANTIES AS TO MERCHANTABILITY OR OTHERWISE ARE MADE. A continuing product research program is ongoing. Airteq reserves the right to incorporate products and specification changes at any time without notice.



SECTION 11 19 20 – DETENTION HARDWARE

2.11 ACCESSORIES

- A. Pass-Through Openings: Fabricate flush openings using 0.093-inch-thick interior channels of same material as detention door faces, inverted to be flush with openings, welded to inside of both face sheets and with corners fully welded. Mount shutters on non-inmate side of detention doors. Reinforce for locks and food-pass hinges.
 - 1. Overlapping Shutters: For surface application on non-inmate side of door. Fabricate from a single steel plate, of same material as detention door face sheets, 0.187 inch thick, sized to overlap scheduled openings 1/2 inch

- B. Cuff Ports: Constructed of tough and corrosion resistant 304 stainless steel port mounted to cell door with automatic self-opening food pass door, piano hinge and security lock.
 - 1. Basis of Design: On the Gate. Manufactured by Airteq Systems, 2511 Midpark Road, Montgomery, AL 36109 or architect approved equal.
 - 2. Mounting Configuration: Center Mount Box/Tray fully interchangeable and transferable from one door to another.
 - 3. Security Lock Type: No.5017 Latch- Paracentric Key.
 - a. 5017 lock in center of frame securing Anti-Splash box assembly.
 - b. 5017 lock automatically raises food pass door.
 - c. 5017 lock opens/secures hinged door to Anti-Splash box assembly.
 - 4. Anti-Splash Box Material: 12 Gage 304 stainless steel with welded strap on assembly preventing tampering with the latch locks.
 - 5. Sliding Door Material: 304 stainless steel.
 - 6. Frame Material: 304 stainless steel.
 - 7. Cover Material: 1/2 inch thick clear Lexan.
 - 8. Hinge: 3/16 inch stainless steel piano hinge.
 - 9. Warranty Period: Two years.”

REVISIONS

ECN #	ZONE	REV.	DESCRIPTION	DATE	APPROVED

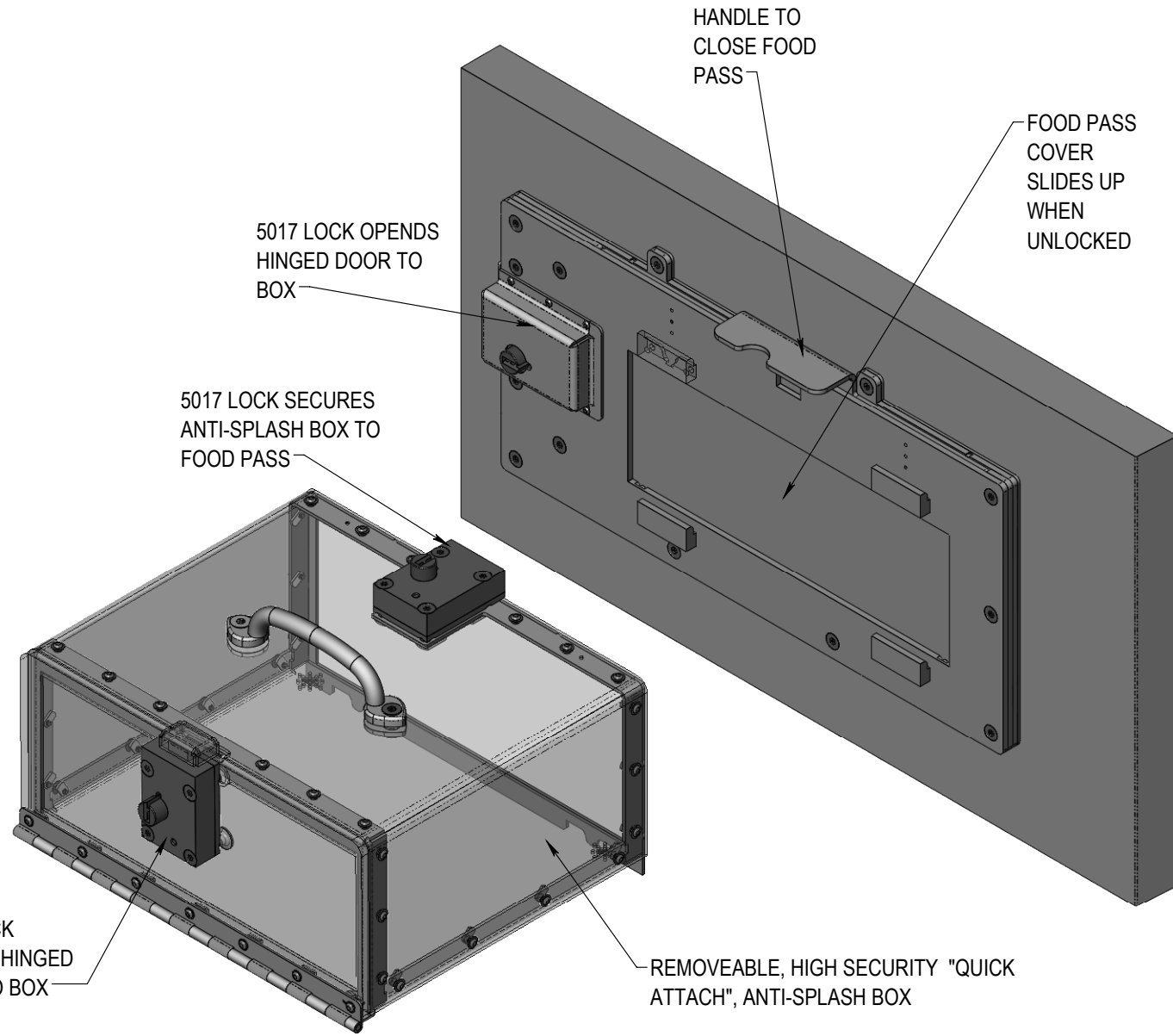

DOOR WITH BOX REMOVED

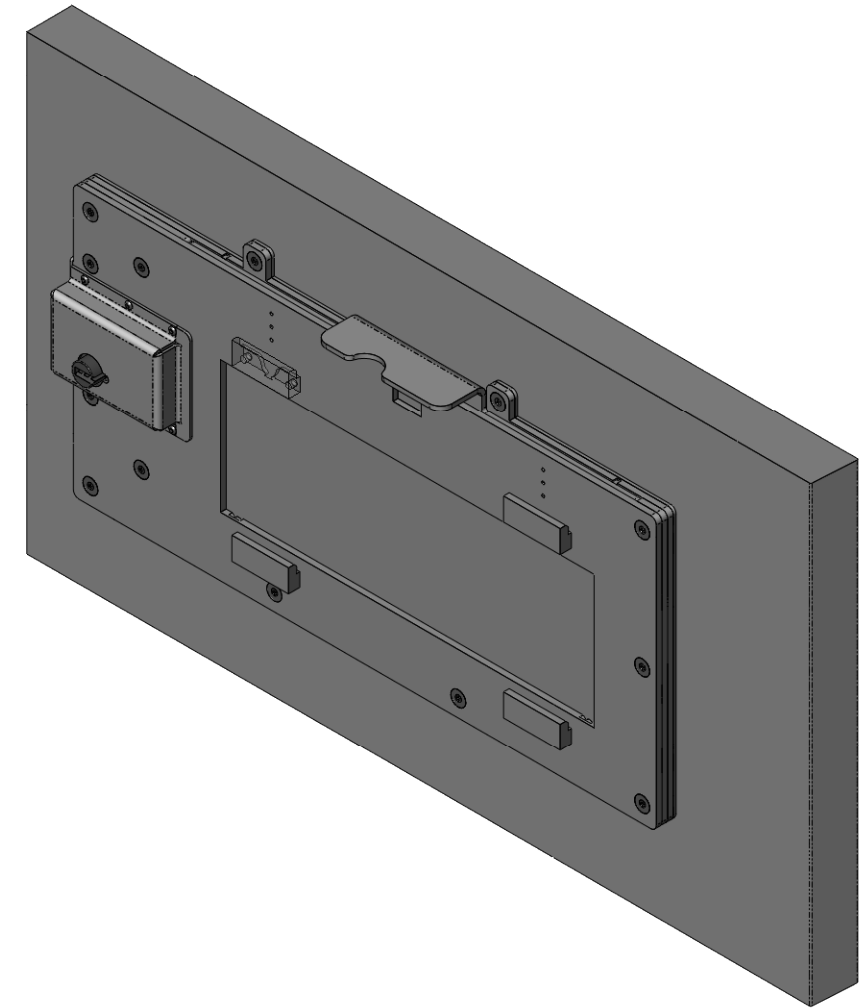

DOOR WITH BOX ATTACHED

AIRTEQ			
TITLE:		DATE	NAME
HIGH SECURITY FOOD PASS (REPLACEMENT)		DRAWN	5/28/20 MER
		CHECKED	
SCALE:	1:8		
SHEET	1 OF 2		
SIZE	DWG. NO.	REV	
B	530-5017-100-R		

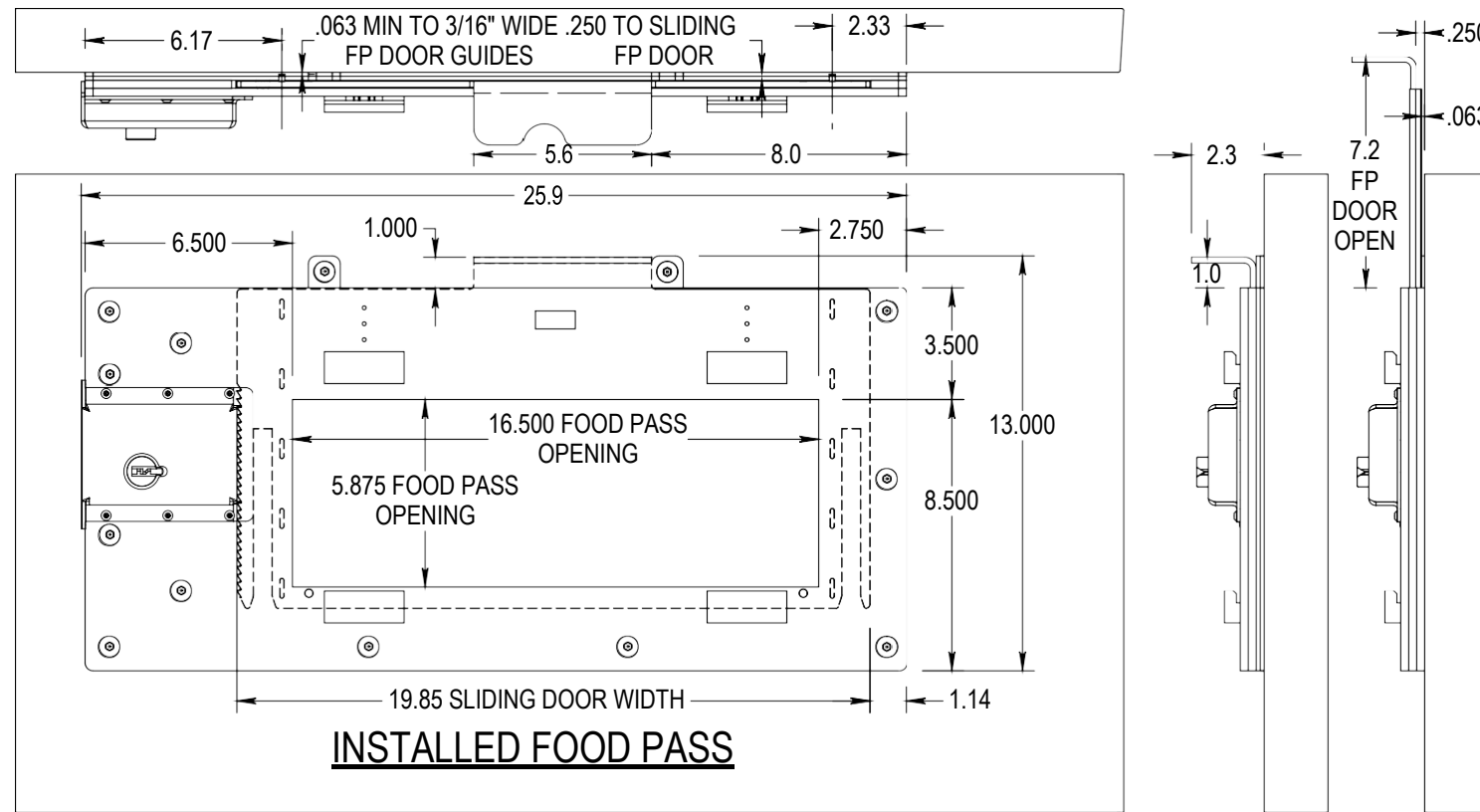

AIR/TEQ			
TITLE:		HIGH SECURITY FOOD PASS	
DRAWN	DATE	CHECKED	NAME
	5/28/20		MER
		SCALE:	1:12
		SHEET	2 OF 2
SIZE	DWG. NO.	REV	
B	530-5017-100		

REVISIONS

ECN #	ZONE	REV.	DESCRIPTION	DATE	APPROVED

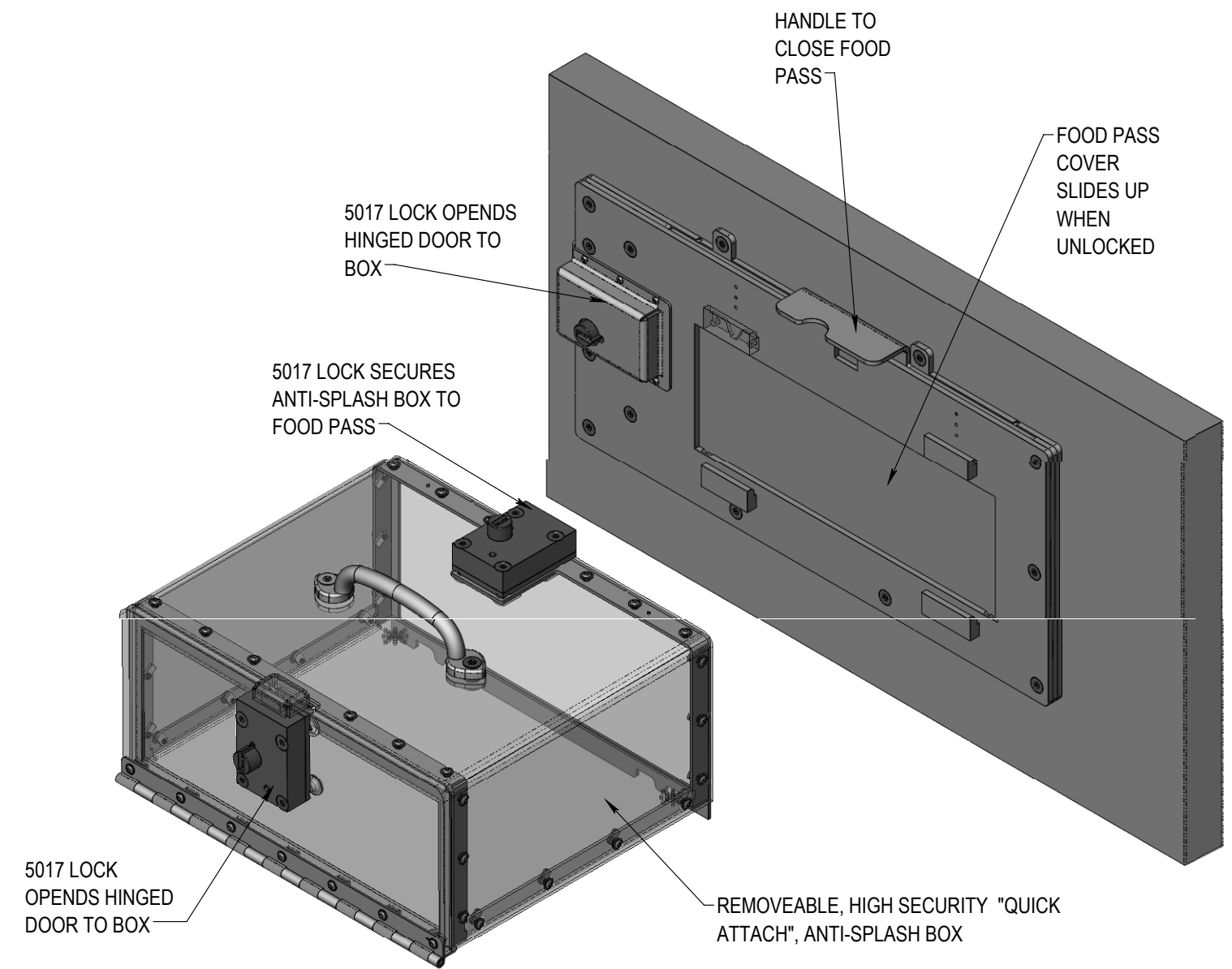

DOOR WITH BOX REMOVED

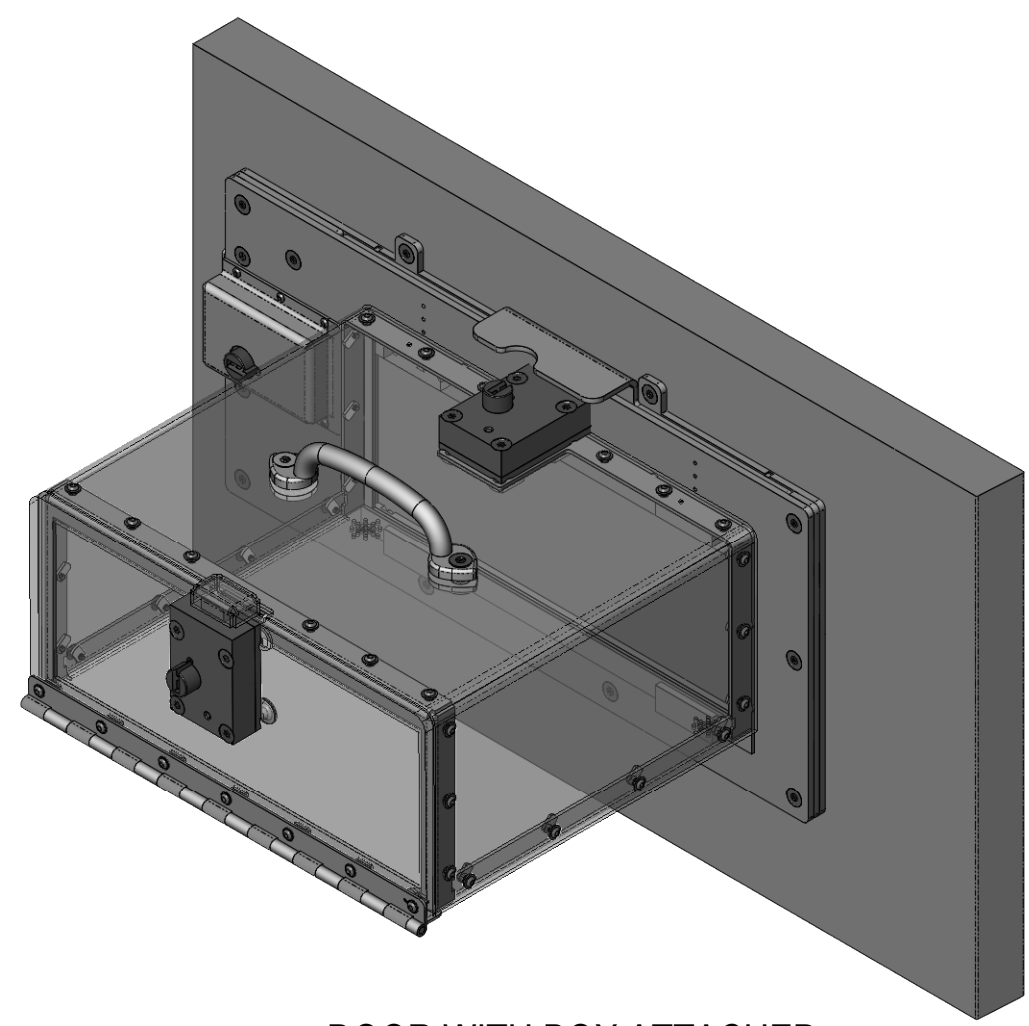

DOOR WITH BOX ATTACHED



TITLE:		DATE		NAME	
HIGH SECURITY FOOD PASS (NEW CONSTRUCTION)		5/28/20		MER	
DRAWN		CHECKED		SCALE:	
				1:8	
SHEET		REV		1 OF 2	
SIZE	DWG. NO.				
B	530-5017-100				

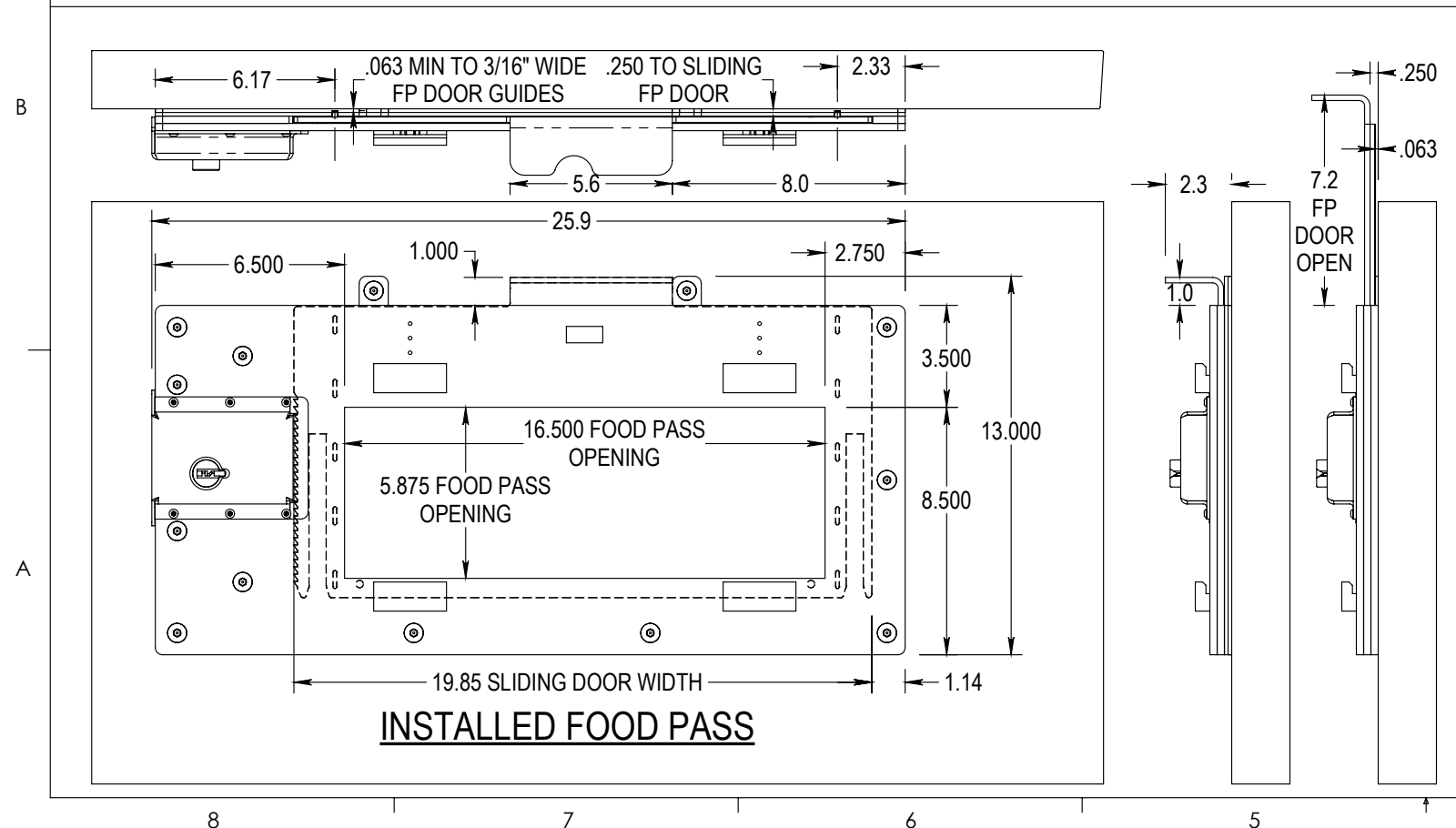
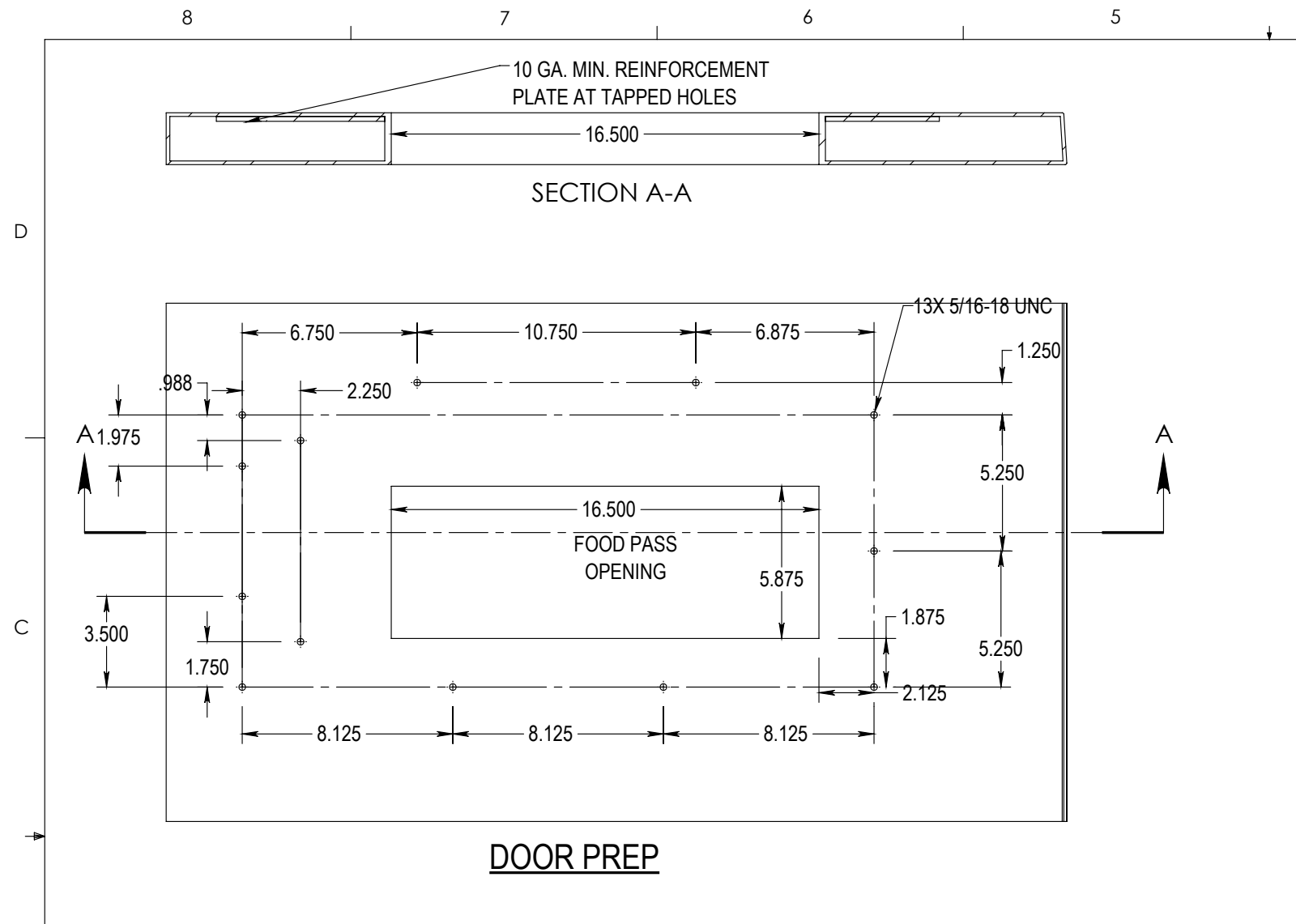

REVISIONS					
ECN #	ZONE	REV.	DESCRIPTION	DATE	APPROVED

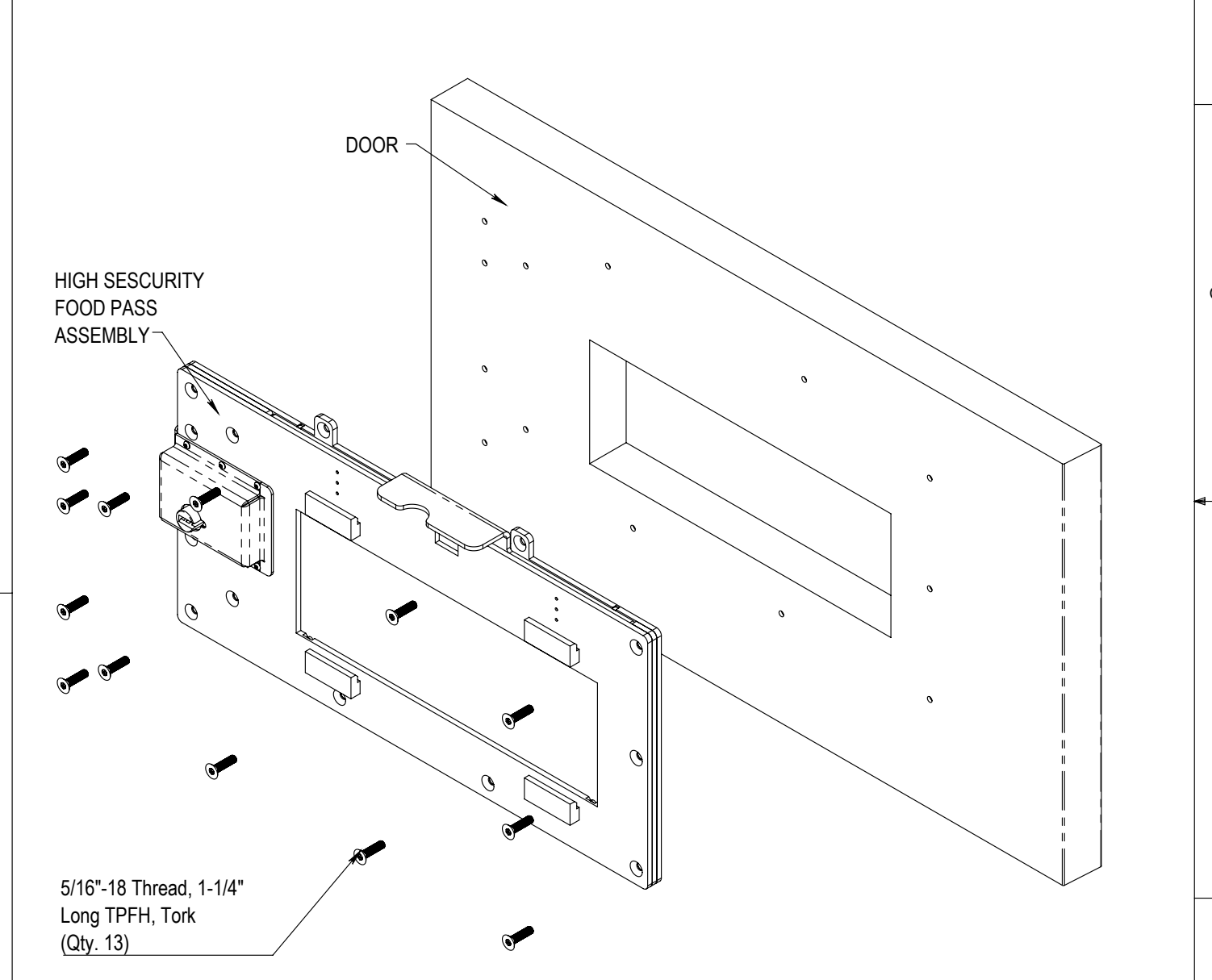

NOTE:

- DRAWING SHOWS ONLY ONE METHOD OF INSTALLATION. INSTALLATION MAY VARY PER DOOR AND FRAME MANUFACTURER.
- ALL DIMENSIONS ARE NOMINAL. DOOR AND FRAME MANUFACTURERS ARE RESPONSIBLE FOR PROVIDING ADEQUATE CONSTRUCTION AND REINFORCEMENT FOR INSTALLATION OF HARDWARE SHOWN.
- ALL DIMENSIONS ARE SUBJECT TO CHANGE WITHOUT NOTICE. USE ONLY CURRENT APPROVED TEMPALTING. ALL DIMENSIONS ARE IN INCHES.

AIR/TEQ

TITLE: **HIGH SECURITY FOOD PASS (NEW CONSTRUCTION)**

DRAWN	5/28/20	DATE	MER	NAME
CHECKED				
SCALE:	1:12			
SHEET	2 OF 2			
SIZE	DWG. NO. 530-5017-100			REV

REVISIONS

ECN #	ZONE	REV.	DESCRIPTION	DATE	APPROVED
		01	ADD NOTE " SHIM AS NEEDED TO ENSURE FOOD PASS IS VERTICAL"	08/05/20	MER

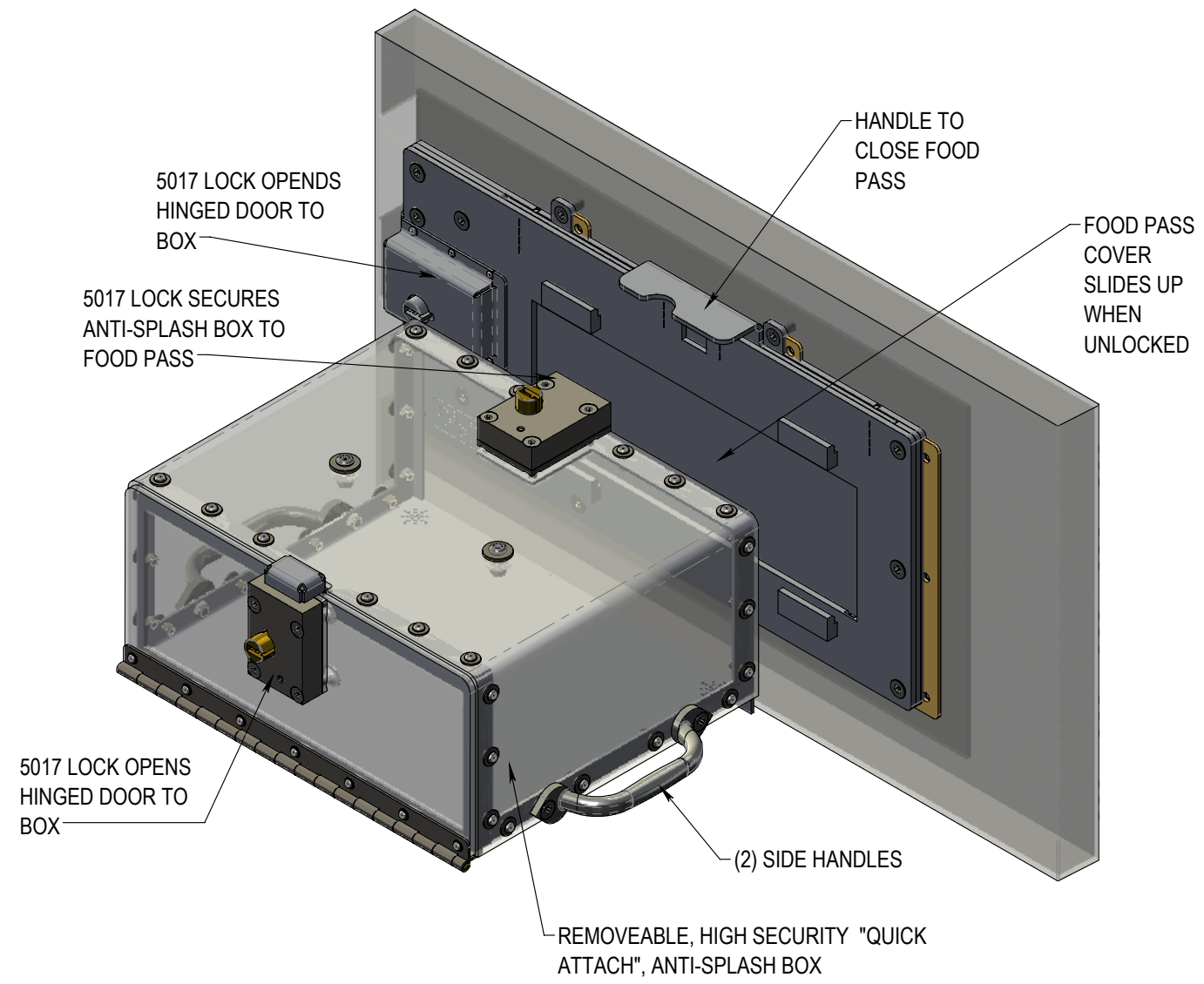

DOOR WITH BOX REMOVED

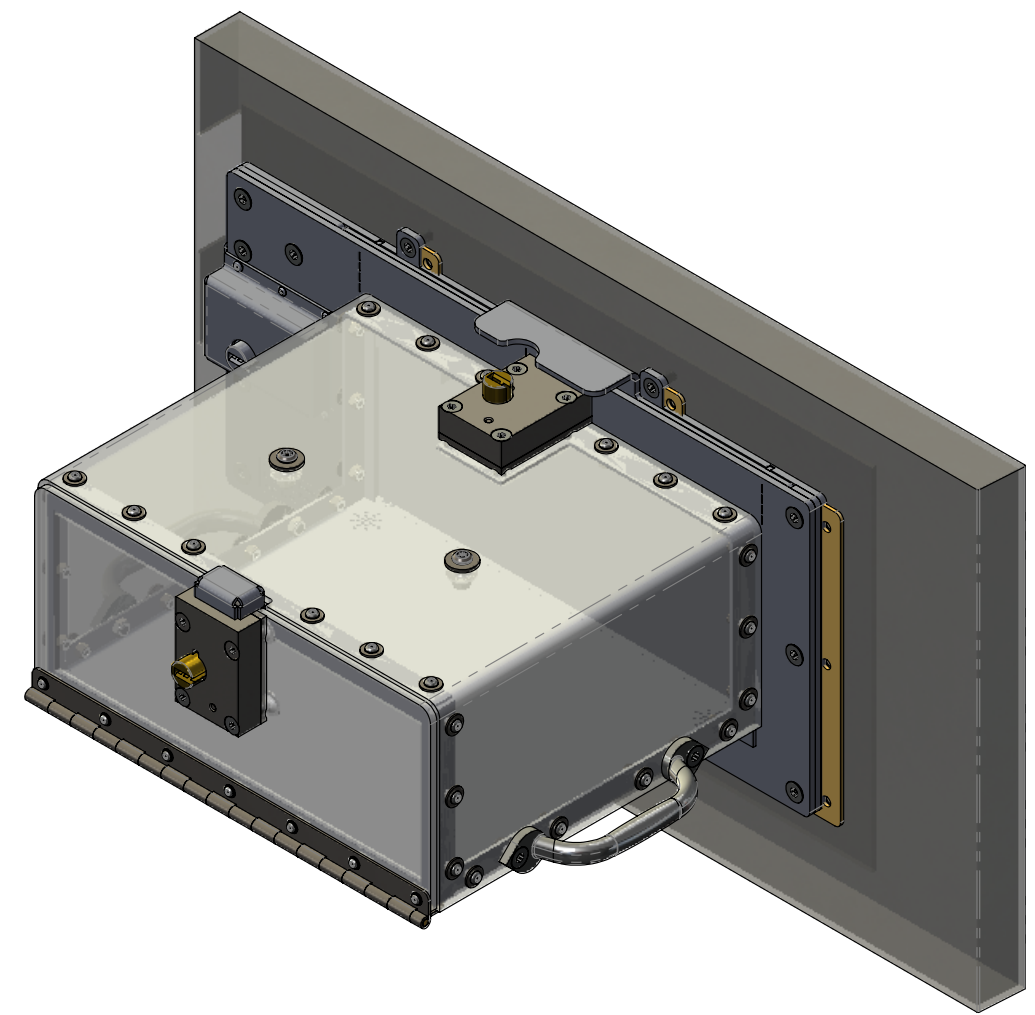

DOOR WITH BOX ATTACHED

AIR/TEQ

TITLE:		DATE		NAME	
HIGH SECURITY FOOD PASS (REPLACEMENT)		DRAWN	5/28/20	MER	
		CHECKED			
SCALE:		1:8			
SHEET		1 OF 2			
SIZE	DWG. NO.	REV			
B	530-5017-100-R				01

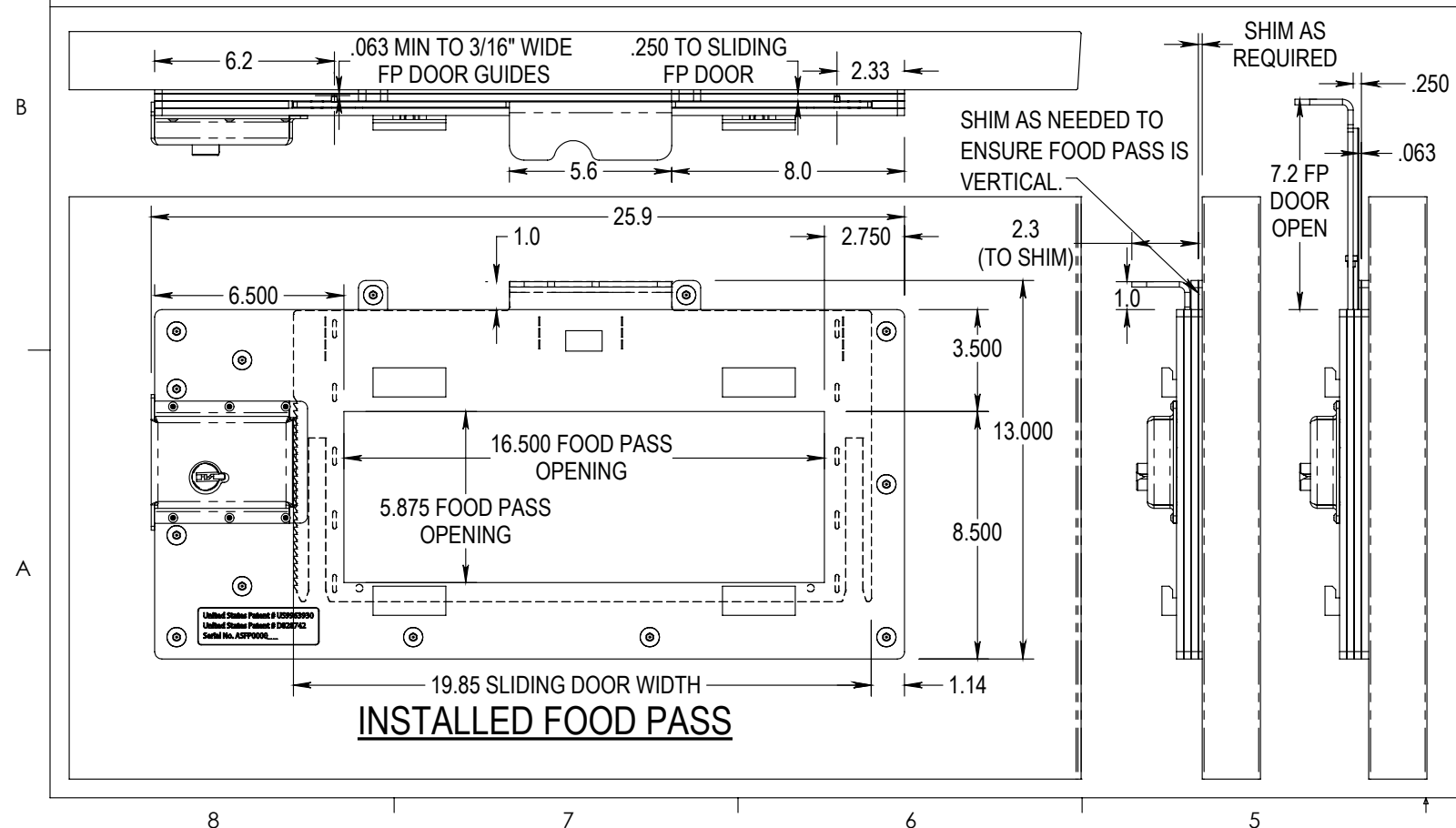
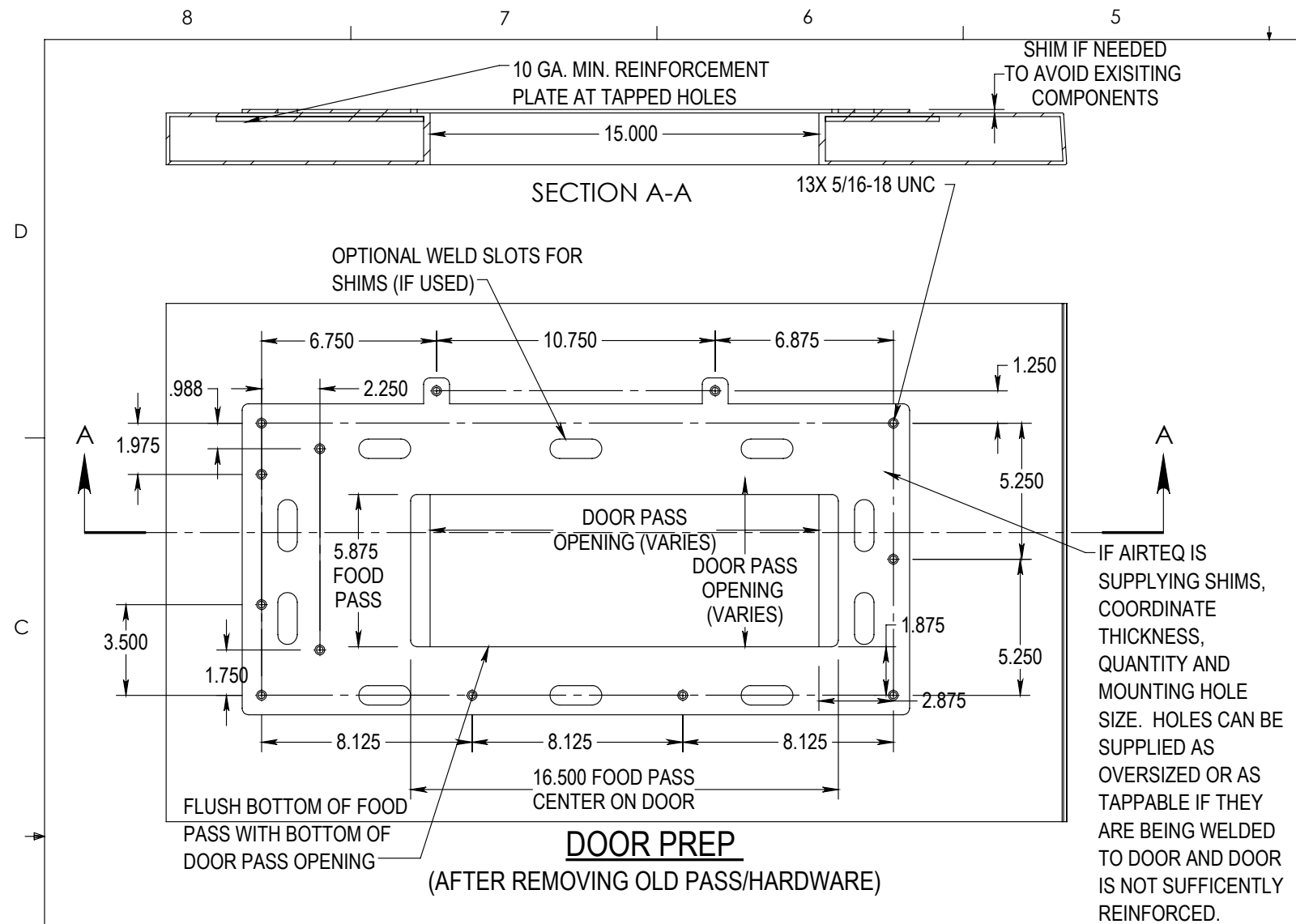

REVISIONS					
ECN #	ZONE	REV.	DESCRIPTION	DATE	APPROVED
		01	ADD NOTE " SHIM AS NEEDED TO ENSURE FOOD PASS IS VERTICAL"	08/05/20	MER

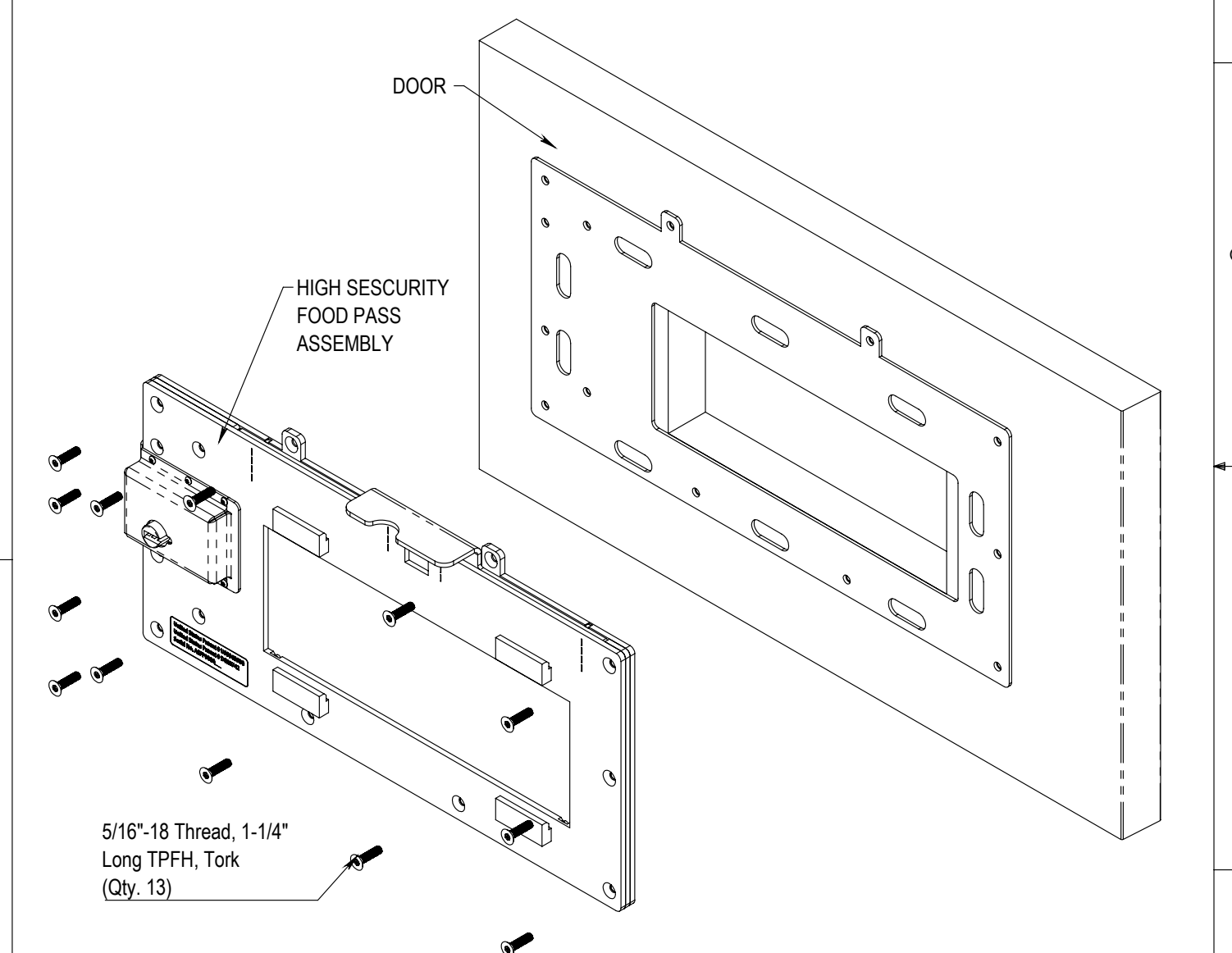

NOTE:
 1. DRAWING SHOWS ONLY ONE METHOD OF INSTALLATION. INSTALLATION MAY VARY PER DOOR AND FRAME MANUFACTURER.
 2. ALL DIMENSIONS ARE NOMINAL. DOOR AND FRAME MANUFACTURERS ARE RESPONSIBLE FOR PROVIDING ADEQUATE CONSTRUCTION AND REINFORCEMENT FOR INSTALLATION OF HARDWARE SHOWN.
 3. ALL DIMENSIONS ARE SUBJECT TO CHANGE WITHOUT NOTICE. USE ONLY CURRENT APPROVED TEMPALTING. ALL DIMENSIONS ARE IN INCHES.

AIRTEQ

TITLE: HIGH SECURITY FOOD PASS (REPLACEMENT)

DRAWN	5/28/20	NAME	MER
CHECKED			
SCALE:	1:12		
SHEET	2 OF 2		
SIZE	DWG. NO.	REV	
B	530-5017-100-R	01	



HIGH SECURITY FOOD PASS WITH ANTI-SPLASH BOX

12/16/20

Care and Maintenance:

The Patented High Security Food Pass with the Anti-Splash Box is constructed primarily of Stainless Steel and Polycarbonate (found on the Anti-Splash Box). It has been engineered and built with only the highest quality materials that should last for many years with only minimal general maintenance.

THE KEY TO KEEPING STAINLESS STEEL "STAINLESS" AND POLYCARBONATE IN GOOD SHAPE REQUIRES PROPER MAINTENANCE AND CARE AS NOTED BELOW:

STAINLESS STEEL

Stainless-Steel can be damaged by abrasive pads, or the wrong kinds of cleaners. Despite its name and reputation, Stainless-Steel can both stain and rust.

If you find that the Stainless-Steel portion of the Anti-Splash Food Pass has become soiled, it can be cleaned as follows:

1. Use a mild soap or mild dish-washing liquid: Mix the soap with water. Wipe the Stainless-Steel with the soapy solution and then rinse thoroughly, ensuring all soap residue is removed.
2. A commercial cleaner designed specifically for Stainless-Steel can be used. Be sure to follow the product directions.
3. You can also use **WD-40**: Simply spray some WD-40 directly onto your Stainless-Steel Frame, or into a rag, and then wipe the **WD-40** away. WD-40 will also provide a layer of protection to the Stainless-Steel.

(NOTE: DO NOT USE WD-40 ON THE POLYCARBONATE FOUND ON THE ANTI-SPLASH BOX!)

Care and Cleaning Procedures for cleaning the Polycarbonate Anti-Splash Box

(Note: Use only products specifically recommended for cleaning polycarbonate such as Novus #1, or Brilliance, and a soft cloth. Never use a dry cloth or your hand to clean the Polycarbonate! This action will rub dirt and dust INTO the Polycarbonate)

Polycarbonate should only be cleaned with a mild detergent, water and a soft cloth.

1. First rinse the Polycarbonate Anti-Splash Box with lukewarm water.
2. Then wash the Box with a mild soap and lukewarm water using a soft cloth or sponge to gently wash the Polycarbonate with an up and down motion preferably in one direction.
3. Repeat this process until the Polycarbonate is clean, then rinse and dry with a soft cloth to prevent water spotting.

What to use and not use in the Care and Cleaning of the Polycarbonate Anti-Splash Box

The following cleaning agents have been found to be compatible with the Polycarbonate used on the Anti-Splash Food Pass Box:

1. Joy Liquid Dish Detergent
2. Freon T.F.
3. Palmolive Liquid Dish Detergent
4. Top Job
5. VM&P Grade Naptha
6. Novus #1
7. Brilliance

The following cleaning agents should **NEVER be used to clean the Polycarbonate used on the Anti-Splash Food Pass Box:**

1. Lysol
2. Pinosol
3. Butyl Cellosolve
4. Isopropanol
5. Formula 409
6. Ammonia
7. Windex with Ammonia

If you have any questions or concerns regarding the care and maintenance of the High Security Food Pass System, please contact Airteq.



HIGH SECURITY FOOD PASS WITH ANTI-SPLASH BOX

12/16/20

Hydraulic Springs Care, Testing and Maintenance

The commercial grade Hydraulic Springs housed within the Anti-Splash System Frame are made with Carbon Steel and are of the highest quality. The 2 Hydraulic Springs housed within the Anti-Splash System controls the rising of the Stainless-Steel Door, and serves as a safety feature that prevents the closing of the Stainless-Steel Door fully without the assistance of the person operating the Door. The Hydraulic Springs must be checked from time to time (recommended every 60 days) to assure that the Hydraulic Springs are functioning properly.

How to check Hydraulic Springs operation:

1. While the Stainless-Steel Door of the Anti-Splash System Frame is closed, place the key in the lock controlling the Stainless-Steel Door.
2. Once the key is in the Door lock, turn the key which will release the Stainless-Steel Door from the Frame locking mechanism.
3. While the key is still being held in the unlock position inside the Door lock, the Stainless-Steel Door should now automatically rise to the 1/3 (approx.) open position. **If the Door fails to automatically rise to the 1/3 open position (approx.), notify AIRTEQ immediately and stop using this Anti-Splash System unit in question until AIRTEQ has been notified, and the condition has been rectified.**
4. Once the Stainless-Steel Door has automatically rise to the 1/3 (approx.) open position, then (with the Door lock key still turned to the open position) manually raise the Door to the full open position. Once the door is in the fully open position, now release the Door lock key. The Door should remain in the fully open position. **If the Door fails to remain in the fully open position, notify AIRTEQ immediately of this condition. Stop using this Anti-Splash System unit in question until AIRTEQ has been notified, and the condition has been rectified.**
5. Once the Stainless-Steel Door is in the fully open position: Without holding the Stainless-Steel Door, turn the key that controls the Door locking device to the open position and allow the Stainless-Steel Door to "FREE FALL". The Stainless-Steel Door should automatically stop 2 to 3 inches above the Door's fully closed position. This is a built-in safety feature that **MUST** function properly.
If the Stainless-Steel Door fails to stop at least 2 to 3 inches above the Door's fully closed position, IMMEDIATELY notify AIRTEQ of this condition, and STOP using the Anti-Splash System unit in question until AIRTEQ has been notified, and the condition has been fully rectified.

If you have any questions or concerns regarding the care and maintenance of the High Security Food Pass System, please contact Airteq.